



ADDENDUM #1 FOR:

RENOVATIONS, ALTERATIONS & ADDITIONS
FOR THE MODERNIZATION OF:

THE HUBBARD MANOR BUILDING #OH-807:

105 WEST LIBERTY STREET, CITY OF HUBBARD,
TRUMBULL COUNTY, STATE OF OHIO, 44425

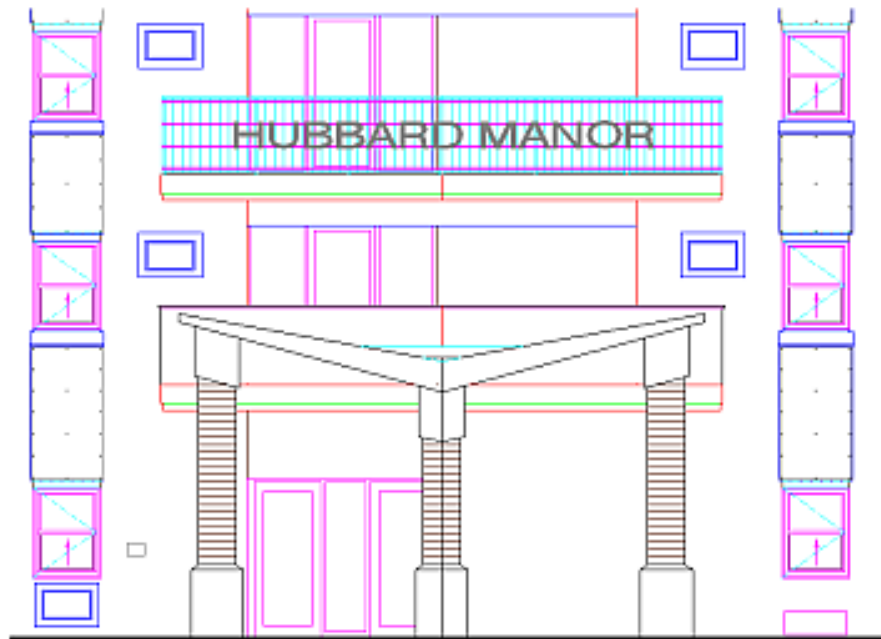

TMHA CONTRACT #9-3A

FOR THE

TRUMBULL METROPOLITAN HOUSING AUTHORITY

4076 Youngstown Road, Suite 101
Warren, Trumbull County, Ohio

Archi-Tekton, Inc, "Atekton"

294 Center Street West, Warren, Ohio 44481
PO Box 201478, Shaker Heights, Ohio 44120

www.atekton.com

detail@atekton.com

330.505.9075, 216.561.1510

216.283.1500 Fax

0901
May 21, 2010

May 21, 2010

ADDENDUM NO. 1

To Drawings and Specifications for the

**Renovations, Alterations & Additions for the Modernization of:
THE HUBBARD MANOR BUILDING #OH-807**

LOCATED AT:

105 West Liberty Street, City of Hubbard, Trumbull County, State of Ohio, 44425

TMHA CONTRACT #9-3A

FOR THE

TRUMBULL METROPOLITAN HOUSING AUTHORITY

4076 Youngstown Road, Suite 101
Warren, Trumbull County, Ohio

To all Bidders,

This Addendum supplements and amends the original Drawings and Specifications and shall be taken into account in preparing proposals and shall become a part of the Contract Documents. Sub-contractors and General Contractors shall review all parts of this addendum since respective information may be stated throughout this addendum; for example, the responsibilities of specific trades cutting and patching is found under only one section of this addendum.

GENERAL INFORMATION

1. **Instructions to Bidders:**
Refer to the new updated Davis-Bacon wage determinations, **Enclosure #1**. The wage rates as stated in the specification booklet are incorrect and are no longer valid.
2. **Instructions to Bidders:**
Refer to Architectural Ceiling Plans for final ceiling layout and diffuser, fan coil unit, sprinkler head locations and light fixtures. Verify with architect final locations if any conflicts occur.
3. **Instructions to Bidders:**
(Dwg. S104): Structural Section D/S103 rear elevation of portico at center shall be 12'-10 1/2"
(Elevation 112'-10 1/2") not 12'-7 1/2"

RENOVATIONS, ALTERATIONS & ADDITIONS FOR
THE MODERNIZATION OF HUBBARD MANOR #OH-807
(TMHA CONTRACT #9-3A)

4. **Instructions to Bidders:**
(Specification Section 16780): DVR Specifications: Change line 11 on Sheet 6 to read; Processing Unit: Pentium 4, 3.0 GHz processor with **1 GB minimum of RAM**. Change line 15 on Sheet 6 to read; Storage: Hard drive with **4 TB or equivalent to minimum 30 days of recording before overwrites**. Change line 24 on Sheet 7 to read; Hard Disk Drives: **4 TB or equivalent to minimum 30 days of recording before overwrites**. DVR software shall have the ability to copy files to Windows Media format, for example avi, wav or any other type of files that are MS Windows format.
5. **Instructions to Bidders:**
Disregard lines 19 thru 26 about Temporary Heat in Specification Section 01500 and refer to lines 26 thru 37 on page 2 of Specification Section 01100 for Temporary Heating.
6. **Instructions to Bidders:**
Note 18 on Sheet IN104 refers to a sheet A602. There is no sheet A602 in this set of construction documents: As a clarification the window size for the apartments is 3'-0" wide by 4'-0" tall. Every opening shall be field verified before placing window order.
7. **Instructions & Clarifications to Bidders:**
All aluminum door panels shall be heavy walled, disregard lines 10 and 11 on sheet 2 of Specification Section 08400. Standard series doors are not relevant to this project. All aluminum door frames shall be heavy walled. Interior store fronts shall receive insulated glass assembly but do not need to receive any low-e glazing. The "FireLite" by TGP designated 60 minute rated glass on the door schedule shall be replaced with "FireLite NT" by TGP. The doors that are called out to be 20 minute rated that receive 1/4" tempered glazing shall be changed to provide 1/4" thick "Fireglass20" by TGP fire rated glazing in the sizes specified in the construction documents.
8. **Clarifications to Bidders:**
All aluminum doors shall be Tuffline 500 series by Kawneer with 5" wide side stiles and tempered, low-e and insulated glazing.
9. **Instructions to Bidders:**
Refer to the new concrete patio section, **Enclosure #2**.
10. **Instructions to Bidders:**
Refer to the new concrete curb and sidewalk section, **Enclosure #3**.
11. **Instructions to Bidders:**
Refer to the new concrete curb and lawn section, **Enclosure #4**.
12. **Instructions to Bidders:**
Refer to the new typical concrete joints sections, **Enclosure #5**.

RENOVATIONS, ALTERATIONS & ADDITIONS FOR
THE MODERNIZATION OF HUBBARD MANOR #OH-807
(TMHA CONTRACT #9-3A)

13. **Instructions to Bidders:**
(Dwg. M101): Emergency generator vent piping to be 4” inside diameter double wall type ‘B’ vent extended up to 4-0” above roof level. Install insulated sleeve at structure penetration.
14. **Instructions to Bidders:**
(Dwgs. M102 & M103): Makeup air ductwork and diffusers on 2nd and 4th floor plans to be similar to systems indicated on 3rd and 5th floor piping (one (1) diffuser per floor).
15. **Instructions to Bidders:**
(Dwg. M104): Refer to drawing M-101 for generator flue and exhaust fan EF-65 locations.
16. **Instructions to Bidders:**
(Dwg. P300): There is to be a new floor drain installed in all apartment bathrooms as indicated on drawing P500. New floor drains are indicated on sanitary riser ‘B’. Floor drains are to be located in similar locations on sanitary riser ‘D’ and sanitary riser ‘F’.
17. **Instructions to Bidders:**
(Dwg. E500): Type 2 Room Layout – Electrical. Type ‘B’ fixture shall be a Progress No. P5103-20 with GE SL-G18/27 lamp.
18. **Instructions to Bidders:**
(Dwg. E500): Type 2 Room Layout – Electrical. Install a cable TV outlet and an antenna system TV outlet in the bedroom on the wall common with the living room. Provide proper splitters as required.
19. **Instructions to Bidders:**
(Dwg. E500): Type 1 Room Layout – Electrical. Install a cable TV outlet and an antenna system TV outlet in the bedroom area on the outside wall between exterior windows. final location shall be confirmed with TMHA and the Architect. Provide proper splitters as required.
20. **Instructions to Bidders:**
(Dwg. E500): Type 1 Room Layout – Electrical. Install a type ‘B’ pendant fixture (Progress No. P5103-20 with GE SL-G18/27 lamp) in dining area. Wire from kitchen lighting circuit. Install a wall switch on wall common with closet.
21. **Instructions to Bidders:**
(Dwg. E500): Apartment No. 104 (Type 2 Layout). Provide a doorbell system for hearing impaired per coded notes 8, 9 & 10. Provide a 120 volt strobe in the bathroom. Wire strobe to operate with single station smoke detectors in apartment.
22. **Instructions to Bidders:**
(Dwg. E500): Apartment No. 101, 102 & 103 (Type 1 Layout). Provide a 120 volt strobe in the bathroom. Wire strobe to operate with single station smoke detectors in apartment.

RENOVATIONS, ALTERATIONS & ADDITIONS FOR
THE MODERNIZATION OF HUBBARD MANOR #OH-807
(TMHA CONTRACT #9-3A)

23. Instructions to Bidders:

(Dwgs E202 & E203): Electrical Ceiling Plans. Delete one type 'R' fixture on normal circuit in East Corridor on floor 2, 3, 4 & 5. Refer to Architectural Ceiling Plans A202 and A203 for fixture locations.

END OF ADDENDUM #1

GENERAL DECISION: OH20100003 05/21/2010 OH3

Date: May 21, 2010

General Decision Number: OH20100003 05/21/2010

Superseded General Decision Number: OH20080003

State: Ohio

Construction Type: Building

Counties: Columbiana, Mahoning and Trumbull Counties in Ohio.

BUILDING CONSTRUCTION PROJECTS (Does not include single family homes and apartments up to and including 4 stories)

Modification Number	Publication Date
0	03/12/2010
1	03/19/2010
2	05/07/2010
3	05/21/2010

ASBE0084-003 07/01/2009

	Rates	Fringes
ASBESTOS WORKER/INSULATOR (Includes application of all insulating materials, protective coverings coatings & finishings to all types of mechanical systems).....	\$ 27.37	13.70

ASBE0207-011 07/01/2009

	Rates	Fringes
HAZARDOUS MATERIAL HANDLER (Includes preparation, wetting, stripping, removal, scrapping, vacuuming, bagging & disposing of all insulation materials, whether they contain asbestos or not, from mechanical systems).....	\$ 23.60	9.80

BOIL0154-006 06/01/2009

COLUMBIANA

	Rates	Fringes
BOILERMAKER.....	\$ 36.70	20.82

BOIL0744-004 07/01/2009

MAHONING & TRUMBULL

	Rates	Fringes
--	-------	---------

BOILERMAKER.....\$ 36.84 17.48

 * BROH0006-011 05/01/2010

COLUMBIANA (Knox, Butler, West & Hanover Townships)

	Rates	Fringes
Bricklayer, Caulker, Cleaner, Pointer & Stonemason.....	\$ 25.95	11.13

 BROH0008-002 06/01/2009

COLUMBIANA (Salem, Perry, Fairfield, Center, Elk Run, Middleton & Unity Townships and the city of New Waterford), MAHONING & TRUMBULL

	Rates	Fringes
Bricklayer, Caulker, Cleaner, Pointer & Stonemason.....	\$ 24.37	14.49

 BROH0008-003 06/01/2009

COLUMBIANA (Center, Elk Run, Fairfield, Middleton, New Waterford, Perry, Salem & Unity Townships) & MAHONING

	Rates	Fringes
Marble Setter, Terrazzo Worker & Tile Setter.....	\$ 24.76	11.19

 BROH0008-005 06/01/2008

COLUMBIANA, MAHONING (Excluding Smith Township) & TRUMBULL

	Rates	Fringes
Marble Setter Finisher, Terrazzo Worker Finisher, Tile Setter Finisher.....	\$ 22.17	10.23

 BROH0010-005 07/01/2009

COLUMBIANA COUNTY (St. Clair, Madison, Wayne, Franklin, Washington, Yellow Creek & Liverpool Townships)

	Rates	Fringes
BRICKLAYER BRICKLAYERS; CAULKERS; CLEANERS; CEMENT BLOCKLAYERS; MARBLE SETTERS; POINTERS; STONEMASONS & TERRAZZO WORKERS.....	\$ 24.70	12.91
TILE FINISHER.....	\$ 20.00	12.91
TILE SETTER.....	\$ 23.00	12.91

CARP0003-001 05/01/2009

MAHONING & TRUMBULL

	Rates	Fringes
Carpenter & Soft Floor Layer.....	\$ 24.12	12.15

CARP0171-004 05/01/2009

COLUMBIANA

	Rates	Fringes
Carpenter & Soft Floor Layer.....	\$ 24.12	12.39

CARP1871-016 05/01/2009

MAHONING & TRUMBULL

	Rates	Fringes
PILEDRIVERMAN.....	\$ 24.87	12.38

CARP1871-018 05/01/2009

MAHONING & TRUMBULL

	Rates	Fringes
MILLWRIGHT.....	\$ 24.87	12.38

CARP1871-021 05/01/2009

COLUMBIANA

	Rates	Fringes
MILLWRIGHT.....	\$ 26.96	12.14

CARP2235-008 01/01/2009

COLUMBIANA

	Rates	Fringes
PILEDRIVERMAN.....	\$ 28.85	12.10
Welder &/or Creosote.....	\$ 29.15	12.10

ELEC0064-002 12/01/2009

COLUMBIANA (Butler, Fairfield, Perry, Salem & Unity Townships)
 MAHONING (Austintown, Beaver, Berlin, Boardman, Canfield,
 Ellsworth, Coitsville, Goshen, Green, Jackson, Poland,
 Springfield & Youngstown Townships) & TRUMBULL (Hubbard &
 Liberty Townships)

	Rates	Fringes
ELECTRICIAN.....	\$ 29.68	12.26

 ELEC0071-007 12/29/2008

	Rates	Fringes
Line Construction		
Equipment Operator.....	\$ 27.45	10.51
Groundman.....	\$ 19.83	8.92
Lineman & Cable Splicers....	\$ 30.50	11.15

 ELEC0246-002 10/26/2009

COLUMBIANA COUNTY (South of Butler, Fairfield, Knox, Salem & Unity Townships)

	Rates	Fringes
ELECTRICIAN.....	\$ 32.50	21.79+a

FOOTNOTE: a. 1 1/2 Paid Holidays: The last scheduled workday prior to Christmas & 4 hours on Good Friday.

 ELEC0540-004 12/28/2009

COLUMBIANA (Knox Township) and MAHONING (Smith Township) COUNTIES

	Rates	Fringes
ELECTRICIAN.....	\$ 27.44	17.27

 ELEC0573-004 03/01/2010

MAHONING (Milton Township) and TRUMBULL (Except Liberty & Hubbard Townships)

	Rates	Fringes
ELECTRICIAN.....	\$ 29.15	13.54

 ELEV0045-003 01/01/2010

	Rates	Fringes
ELEVATOR MECHANIC.....	\$ 39.52	20.035+a+b

PAID HOLIDAYS:

a. New Year's Day, Memorial Day, Independence Day, Labor Day, Vetern's Day, Thanksgiving Day, the Friday after Thanksgiving, and Christmas Day.

b. Employer contributes 8% of regular hourly rate to vacation pay credit for employee who has worked in business more than 5 years; 6% for less than 5 years' service.

 ENGI0066-023 06/01/2009

COLUMBIANA, MAHONING & TRUMBULL COUNTIES

	Rates	Fringes
OPERATOR: Power Equipment ASBESTOS; HAZARDOUS/TOXIC WASTE PROJECTS		
GROUP 1 - A & B.....\$ 34.67 ASBESTOS; HAZARDOUS/TOXIC WASTE PROJECTS		14.36
GROUP 2 - A & B.....\$ 34.34 ASBESTOS; HAZARDOUS/TOXIC WASTE PROJECTS		14.36
GROUP 3 - A & B.....\$ 31.22 ASBESTOS; HAZARDOUS/TOXIC WASTE PROJECTS		14.36
GROUP 4 - A & B.....\$ 27.61 ASBESTOS; HAZARDOUS/TOXIC WASTE PROJECTS		14.36
GROUP 5 - A & B.....\$ 24.30 HAZARDOUS/TOXIC WASTE PROJECTS		14.36
GROUP 1 - C & D.....\$ 31.78 HAZARDOUS/TOXIC WASTE PROJECTS		14.36
GROUP 2 - C & D.....\$ 31.48 HAZARDOUS/TOXIC WASTE PROJECTS		14.36
GROUP 3 - C & D.....\$ 28.62 HAZARDOUS/TOXIC WASTE PROJECTS		14.36
GROUP 4 - C & D.....\$ 25.31 HAZARDOUS/TOXIC WASTE PROJECTS		14.36
GROUP 5 - C & D.....\$ 22.28 ALL OTHER WORK		14.36
GROUP 1.....\$ 28.89 ALL OTHER WORK		14.36
GROUP 2.....\$ 28.62 ALL OTHER WORK		14.36
GROUP 3.....\$ 26.02 ALL OTHER WORK		14.36
GROUP 4.....\$ 23.01 ALL OTHER WORK		14.36
GROUP 5.....\$ 20.25		14.36
GROUP 1 - Rig, Pile Driver or Caisson Type; & Rig, Pile		

Hydraulic Unit Attached

GROUP 2 - Asphalt Heater Planer; Backfiller with Drag Attachment; Backhoe; Backhoe with Shear attached; Backhoe-Rear Pivotal Swing; Batch Plant-Central Mix Concrete; Batch Plant, Portable concrete; Berm Builder-Automatic; Boat Derrick; Boat-Tug; Boring Machine Attached to Tractor; Bullclam; Bulldozer; C.M.I. Road Builder & Similar Type; Cable Placer & Layer; Carrier-Straddle; Carryall-Scraper or Scoop; Chicago Boom; Compactor with Blade Attached; Concrete Saw (Vermeer or similar type); Concrete Spreader Finisher; Combination, Bidwell Machine; Crane; Crane-Electric Overhead; Crane-Rough Terrain; Crane-Side Boom; Crane-Truck; Crane-Tower; Derrick-Boom; Derrick-Car; Digger-Wheel (Not trencher or road widener); Double Nine; Drag Line; Dredge; Drill-Kenny or Similar Type; Easy Pour Median Barrier Machine (or similar type); Electromatic; Frankie Pile; Gradall; Grader; Gurry; Self-Propelled; Heavy Equipment Robotics Operator/Mechanic; Hoist-Monorail; Hoist-Stationary & Mobile Tractor; Hoist, 2 or 3 drum; Horizontal Directional Drill Operator; Jackall; Jumbo Machine; Kocal & Kuhlman; Land-Seagoing Vehicle; Loader, Elevating; Loader, Front End; Loader, Skid Steer; Locomotive; Mechanic/Welder; Metro Chip Harvester with Boom; Mucking Machine; Paver-Asphalt Finishing Machine; Paver-Road Concrete; Paver-Slip Form (C.M.I. or similar); Place Crete Machine with Boom; Post Driver (Carrier mounted); Power Driven Hydraulic Pump & Jack (When used in Slip Form or Lift Slab Construction); Pump Crete Machine; Regulator-Ballast; Hydraulic Power Unit not attached to Rig for Pile Drillings; Rigs-Drilling; Roto Mill or similar Full Lane (8' Wide & Over); Roto Mill or similar type (Under 8'); Shovel; Slip Form Curb Machine; Speedwing; Spikemaster; Stonecrusher; Tie Puller & Loader; Tie Tamper; Tractor-Double Boom; Tractor with Attachments; Truck-Boom; Truck-Tire; Trench Machine; Tunnel Machine (Mark 21 Java or similar); & Whirley (or similar type)

GROUP 3 - Asphalt Plant; Bending Machine (Pipeline or similar type); Boring machine, Motor Driven; Chip Harvester without Boom; Cleaning Machine, Pipeline Type; Coating Machine, Pipeline Type; Compactor; Concrete Belt Placer; Concrete Finisher; Concrete Planer or Asphalt; Concrete Spreader; Elevator; Fork Lift (Home building only); Fork Lift Walk Behind (Hoisting over 1 buck high); Form Line Machine; Grease Truck operator; Grout Pump; Gunnite Machine; Horizontal Directional Drill Locator; Single Drum Hoist with or without Tower; Huck Bolting Machine; Hydraulic Scaffold (Hoisting building materials); Paving Breaker (Self-propelled or Ridden); Pipe Dream; Pot Fireperson (Power Agitated); Refrigeration Plant; Road Widener; Roller; Sasgen Derrick; Seeding Machine; Soil Stabilizer (Pump type); Spray Cure Machine, Self-Propelled; Straw Blower Machine; Sub-Grader; Tube Finisher or Broom C.M.I. or similar type; & Tugger Hoist

GROUP 4 - Air Curtain Destructor & Similar Type; Batch Plant-Job Related; Boiler Operator; Compressor; Conveyor; Curb Builder, self-propelled; Drill Wagon; Fork lift &

Lulls; Generator Set; Generator-Steam; Heater-Portable Power; Hydraulic Manipulator Crane; Jack-Hydraulic Power driven; Jack-Hydraulic (Railroad); Ladavator; Minor Machine Operator; Mixer-Concrete; Mulching Machine; Pin Puller; Power Broom; Pulverizer; Pump; Road Finishing Machine (Pull Type); Saw-Concrete-Self-Propelled (Highway Work); Signal Person; Spray Cure Machine-Motor Powered; Stump Cutter; Tractor; Trencher Form; Water Blaster; Steam Jenny; Syphon; Vibrator-Gasoline; & Welding Machine

GROUP 5 - Brakeperson; Fireperson; & Oiler

 IRON0207-005 06/01/2009

COLUMBIANA (E. of a line from Damascus to Highlandtown),
 MAHONING (N. of Old Route #224) & TRUMBULL

	Rates	Fringes
IRONWORKER		
Layout; Sheeter.....	\$ 27.66	16.83
Ornamental; Reinforcing; Structural.....	\$ 26.66	16.83

 IRON0550-002 05/01/2009

COLUMBIANA (W. of a line from Damascus to Highlandtown) &
 MAHONING (S. of Old Rte #224)

	Rates	Fringes
Ironworkers:Structural, Ornamental and Reinforcing.....	\$ 24.63	16.32

 LABO0125-001 06/01/2009

MAHONING & TRUMBULL

	Rates	Fringes
LABORER		
HAZARDOUS WASTE		
Level A.....	\$ 23.76	7.45
Level B.....	\$ 23.63	7.45
Level C.....	\$ 23.50	7.45
Level D.....	\$ 23.37	7.45
ALL OTHER WORK		
GROUP 1.....	\$ 23.07	7.45
GROUP 2.....	\$ 23.19	7.45
GROUP 3.....	\$ 23.31	7.45
GROUP 4.....	\$ 23.38	7.45
GROUP 5.....	\$ 23.57	7.45

LABORER CLASSIFICATIONS

GROUP 1: Building & Construction Laborer; Asphalt Paving;
 Railroad Labor Construction; Carpenter Tender; Asbestos
 Removal

GROUP 2: Mortar Mixer (Hand or Machine); Mason Tender;

Jackhammer Operator; All Machine Driven Tools (Electric, gas or air) & operation of all Pumps Under 4"; Spiker; All Laborers Working in Concrete Such as Pouring, Puddling, Raking & Conveying; All Scaffold Help; Scrap Iron Burning

GROUP 3: Hod Carrier; Rough Terrain Forklift Driver when tending Masons; Work Done by Laborers 7' or more in Depth

GROUP 4: Laborer (Except Jackhammer) Working on Repair of Blast Furnace or Coke Plant & Auxiliary Facilities; Jackhammer Operator in Trench or Shaft 7' or more in depth; Concrete Buster; Pipelayer; Powder & Dynamite; Jackhammer on Blast Furnace or Coke Plant & Auxiliary Facilities

GROUP 5: Wrench Laborer; Miner - Air Tool; Guniting & Sandblasting; Pumpcrete Operations; Build Up Rates - Blast Furnace; Ram Tight; Bellman & Hook-up Man; Lancing Blast Furnace

LABO0809-003 07/01/2009

COLUMBIANA

	Rates	Fringes
LABORER.....	\$ 21.82	8.45

Asbestos Work; Hazardous Waste Work; Instrument & Laser; and Lead Based Paint Removal - Additional \$.50 per hour

Hot Pay - Additional \$1.00 per hour when working with other crafts receiving hot pay

PAIN0476-002 06/01/2009

	Rates	Fringes
PAINTER		
GROUP 1.....	\$ 23.15	9.20
GROUP 2.....	\$ 23.35	9.20
GROUP 3.....	\$ 23.36	9.20
GROUP 4.....	\$ 23.40	9.20
GROUP 5.....	\$ 23.65	9.20
GROUP 6.....	\$ 23.80	9.20
GROUP 7.....	\$ 24.05	9.20

PAINTER CLASSIFICATIONS:

GROUP 1: Painters, Brush & Roller

GROUP 2: Drywall - Hand Finisher

GROUP 3: Structural Steel

GROUP 4: Wallpaper Hanger - Furnishing Own Tools

GROUP 5: Spray, Except Bar Joist/Deck

GROUP 6: Drywall - Mechanical Tools; Epoxy/Mastic; Spray-Bar Joist/Deck; Working Above 50 feet; and Swingstages

GROUP 7: Sandblasting

PAIN0639-001 05/01/2010

	Rates	Fringes
Sign Painter & Erector.....	\$ 20.23	3.25+a+b+c

FOOTNOTES: a. 7 Paid Holidays: New Year's Day; Memorial Day;
July 4th; Labor Day; Thanksgiving Day; Christmas Day & 1
Floating Day

b. Vacation Pay: After 1 year's service - 5 days' paid
vacation; After 2, but less than 10 years' service - 10
days' paid vacation; After 10, but less than 20 years'
service - 15 days' paid vacation; After 20 years' service -
20 days' paid vacation

c. Funeral leave up to 3 days maximum paid leave for death of
mother, father, brother, sister, spouse, child,
mother-in-law, father-in-law, grandparent and inlaw
provided employee attends funeral

PAIN0847-002 06/01/2009

	Rates	Fringes
GLAZIER.....	\$ 25.16	11.54

PLAS0179-001 06/01/2009

	Rates	Fringes
CEMENT MASON/CONCRETE FINISHER...	\$ 27.11	12.15

PLAS0179-002 06/01/2009

	Rates	Fringes
PLASTERER.....	\$ 26.45	11.46

PLUM0396-002 06/01/2009

COLUMBIANA (Excluding Washington & Yellow Creek Townships &
Liverpool Township, Secs. 35 & 36, West of County Road #427),
MAHONING & TRUMBULL

	Rates	Fringes
PLUMBER/PIPEFITTER.....	\$ 27.16	14.81

PLUM0495-003 06/01/2009

COLUMBIANA COUNTY (Washington & Yellow Creek Townships and
Liverpool Township - Sections #35 & #36 - west of County Road
#427)

	Rates	Fringes
Plumber, Pipefitter, Steamfitter.....	\$ 30.73	15.23

 ROOF0071-004 06/01/2009

	Rates	Fringes
ROOFER, Including Built Up, Composition and Single Ply Roofs.....	\$ 21.40	13.48

 SFOH0669-003 01/01/2010

	Rates	Fringes
SPRINKLER FITTER.....	\$ 32.70	16.85

 SHEE0033-007 06/01/2009

	Rates	Fringes
Sheet metal worker.....	\$ 27.66	14.85

 TEAM0092-004 07/01/2008

COLUMBIANA COUNTY

	Rates	Fringes
Truck drivers:		
GROUP 1.....	\$ 21.39	9.87
GROUP 2.....	\$ 21.43	9.87
GROUP 3.....	\$ 21.47	9.87
GROUP 4.....	\$ 22.17	9.87
GROUP 5.....	\$ 22.29	9.87

CLASSIFICATIONS

GROUP 1 - End Dump; Dumpster; Turnarocker; Ross Carrier;
 Athry Wagon; Greaser; Tiremen; Articulated Dump

GROUP 2 - Flatboy Material Tuck, Dump & and Semi-Dump
 Truck; Semi Trailer & Tractor Trailer

GROUP 3 - Tank Trucks (straight & semi)

GROUP 4 - Mechanic

GROUP 5 - Lowboy Trailer; Winch Truck; A-Frame; Forktruck;
 Distributor Truck (front & back end) & Truck Crane

 TEAM0377-004 06/01/2009

MAHONING & TRUMBULL COUNTIES

	Rates	Fringes
TRUCK DRIVER		
GROUP 1.....	\$ 22.42	11.51
GROUP 2.....	\$ 22.99	11.51

TRUCK DRIVER CLASSIFICATIONS

GROUP 1 - Dump; Water; Stake Body; Batch; Flat Bottom; Pick Up; Tandem

GROUP 2 - Semi; Semi Water; Mixer; Fuel; Distributor; Carry All; Euclid Wagon; DW 10 Caterpillar (Equivalent); Tractor Trailer (Low Boy); Tri-axel

WELDERS - Receive rate prescribed for craft performing operation to which welding is incidental.
=====

Unlisted classifications needed for work not included within the scope of the classifications listed may be added after award only as provided in the labor standards contract clauses (29CFR 5.5 (a) (1) (ii)).

In the listing above, the "SU" designation means that rates listed under the identifier do not reflect collectively bargained wage and fringe benefit rates. Other designations indicate unions whose rates have been determined to be prevailing.

WAGE DETERMINATION APPEALS PROCESS

1.) Has there been an initial decision in the matter? This can be:

- * an existing published wage determination
- * a survey underlying a wage determination
- * a Wage and Hour Division letter setting forth a position on a wage determination matter
- * a conformance (additional classification and rate) ruling

On survey related matters, initial contact, including requests for summaries of surveys, should be with the Wage and Hour Regional Office for the area in which the survey was conducted because those Regional Offices have responsibility for the Davis-Bacon survey program. If the response from this initial contact is not satisfactory, then the process described in 2.) and 3.) should be followed.

With regard to any other matter not yet ripe for the formal process described here, initial contact should be with the Branch of Construction Wage Determinations. Write to:

Branch of Construction Wage Determinations
Wage and Hour Division
U.S. Department of Labor
200 Constitution Avenue, N.W.
Washington, DC 20210

2.) If the answer to the question in 1.) is yes, then an interested party (those affected by the action) can request review and reconsideration from the Wage and Hour Administrator

(See 29 CFR Part 1.8 and 29 CFR Part 7). Write to:

Wage and Hour Administrator
U.S. Department of Labor
200 Constitution Avenue, N.W.
Washington, DC 20210

The request should be accompanied by a full statement of the interested party's position and by any information (wage payment data, project description, area practice material, etc.) that the requestor considers relevant to the issue.

3.) If the decision of the Administrator is not favorable, an interested party may appeal directly to the Administrative Review Board (formerly the Wage Appeals Board). Write to:

Administrative Review Board
U.S. Department of Labor
200 Constitution Avenue, N.W.
Washington, DC 20210

4.) All decisions by the Administrative Review Board are final.

=====

END OF GENERAL DECISION

PATIO TO BE 6" THK
CONCRETE SLAB w/ 6x6
W1.4xW1.4 W.W.F. @ 6" MIN.
COMP. AGGREGATE BASE

NOTE No.1:

INSTALL EXPANSION JOINTS @ 30'-0" c/c MAX.
INSTALL 1/2" dia. DOWEL, 3'-0" LONG w/ ONE END
WRAPPED IN FELT AT EACH EXPANSION JOINT.
PROVIDE CONTROL JOINTS @ 5'-0" C/C MAX OR AS SHOWN.

NOTE No.2:

REMOVE ALL EXISTING PAVED MATERIAL & AGGREGATE
AND HAUL AWAY, DO NOT USE EXISTING MATERIAL AS
FILL or BASE MATERIAL.

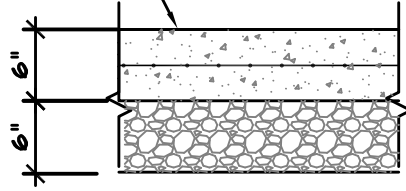

DETAIL - PATIO

SCALE: 3/4" = 1'-0"

SIDEWALK TO BE 6" THK
 CONCRETE SLAB w/ 6x6
 W1.4xW1.4 W.W.F. @ 6" MIN.
 COMP. AGGREGATE BASE
 1/2" EXPANSION JOINT

ODOT ITEM 609 - TYPE 6 -
 6" CONCRETE CURB w/ 1"
 SLOPED FACE. TOP OF CURB
 6" ABOVE TOP OF PAVING.
 EXCEPT AT SIDEWALKS
 THAT MEET ANSI A117.1

REFER TO PLANS AND DETAILS
 FOR PAVEMENT SECTION

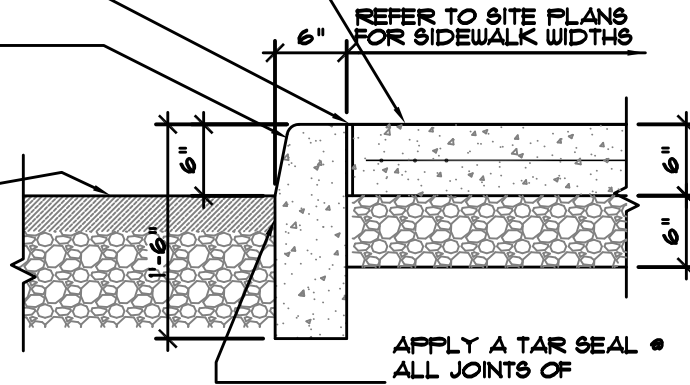

REFER TO SITE PLANS
 FOR SIDEWALK WIDTHS

APPLY A TAR SEAL @
 ALL JOINTS OF
 ASPHALT PAVEMENT &
 CONCRETE CURB

NOTE No.1:

INSTALL EXPANSION JOINTS @ 30'-0" c/c MAX.
 INSTALL 1/2" dia. DOWEL, 3'-0" LONG w/ ONE END
 WRAPPED IN FELT AT EACH EXPANSION JOINT.
 PROVIDE CONTROL JOINTS @ 5'-0" C/C MAX OR AS SHOWN.

NOTE No.2:

REMOVE ALL EXISTING PAVED MATERIAL & AGGREGATE
 AND HAUL AWAY, DO NOT USE EXISTING MATERIAL AS
 FILL or BASE MATERIAL.

NOTE No.3:

THE CURB SHOWN IN THIS DETAIL IS NEW, BUT THERE
 WILL BE NEW AND USED CURBS ON THIS PROJECT AS
 FOLLOWS:

- a) THIS PROJECT IS RE-USING SOME OF THE EXISTING CURB, HOWEVER, SHOULD ANY CURB BECOME DAMAGED AS A RESULT OF THIS PROJECT, THE CONTRACTOR IS REQUIRED TO CUT OUT THE SECTION AND REPLACE. (match the size, shape & profile of the adj. curb) (the minimum length for cutting out and replacing a curb section shall be 10')
- b) IN ADDITION TO AREAS IDENTIFIED ON THE DRAWINGS TO BE REPLACED, & IN ADDITION TO ANY QUANTITY OF CURB THAT IS BEING REPLACED AS A RESULT OF DAMAGE (if any), THE BASE BID SHALL ALSO INCLUDE AN ADDITIONAL 50 lin. ft. (5' sections min.) OF NEW CURB PER SITE, LOCATION TO BE DETERMINED IN FIELD BY ARCHITECT. (this is in the Base Bid and is above and beyond any quantity shown)

DETAIL - CURB & SIDEWALK

MISC. AREAS

SCALE: 3/4" = 1'-0"

RESTORE LAWN AREA TO MATCH ADJACENT LAWN
PLACE ON 6" MIN. BASE OF TOPSOIL

ODOT ITEM 603 - TYPE 6 -
6" CONCRETE CURB w/ 1" SLOPED FACE. TOP OF CURB 6" ABOVE TOP OF PAVING. EXCEPT AT SIDEWALKS THAT MEET ANSI A117.1

REFER TO PLANS AND DETAILS FOR PAVEMENT SECTION

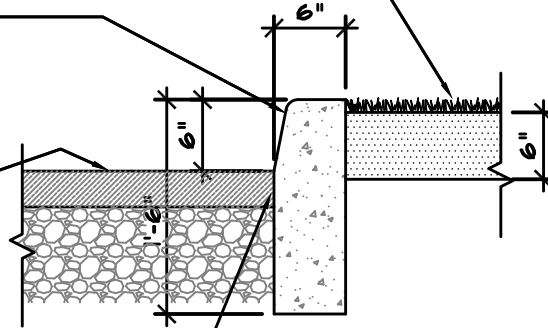

APPLY A TAR SEAL @ ALL JOINTS OF ASPHALT PAVEMENT & CONCRETE CURB

NOTE No.1:

INSTALL EXPANSION JOINTS @ 30'-0" c/c MAX.
INSTALL 1/2" dia. DOWEL, 3'-0" LONG w/ ONE END WRAPPED IN FELT AT EACH EXPANSION JOINT.
PROVIDE CONTROL JOINTS @ 5'-0" C/C MAX OR AS SHOWN.

NOTE No.2:

REMOVE ALL EXISTING PAVED MATERIAL & AGGREGATE AND HAUL AWAY, DO NOT USE EXISTING MATERIAL AS FILL or BASE MATERIAL.

NOTE No.3:

THE CURB SHOWN IN THIS DETAIL IS NEW, BUT THERE WILL BE NEW AND USED CURBS ON THIS PROJECT AS FOLLOWS:

- a) THIS PROJECT IS RE-USING SOME OF THE EXISTING CURB, HOWEVER, SHOULD ANY CURB BECOME DAMAGED AS A RESULT OF THIS PROJECT, THE CONTRACTOR IS REQUIRED TO CUT OUT THE SECTION AND REPLACE. (match the size, shape & profile of the adj. curb) (the minimum length for cutting out and replacing a curb section shall be 10')
- b) IN ADDITION TO AREAS IDENTIFIED ON THE DRAWINGS TO BE REPLACED, & IN ADDITION TO ANY QUANTITY OF CURB THAT IS BEING REPLACED AS A RESULT OF DAMAGE (if any), THE BASE BID SHALL ALSO INCLUDE AN ADDITIONAL 50 lin. ft. (5' sections min.) OF NEW CURB PER SITE, LOCATION TO BE DETERMINED IN FIELD BY ARCHITECT. (this is in the Base Bid and is above and beyond any quantity shown)

DETAIL - CURB & LAWN

SCALE: 3/4" = 1'-0"

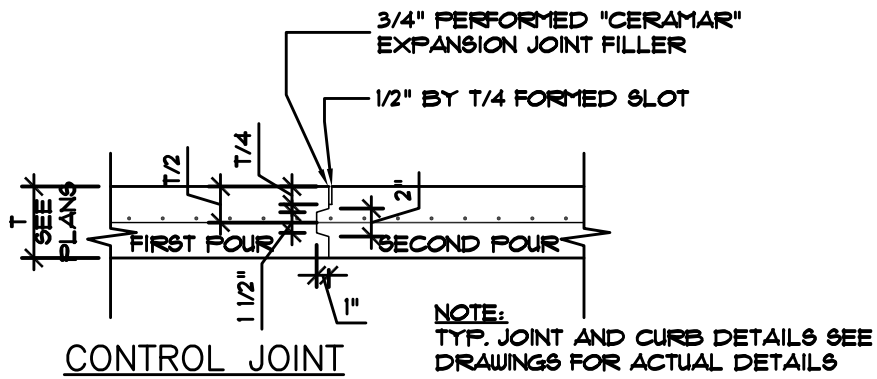
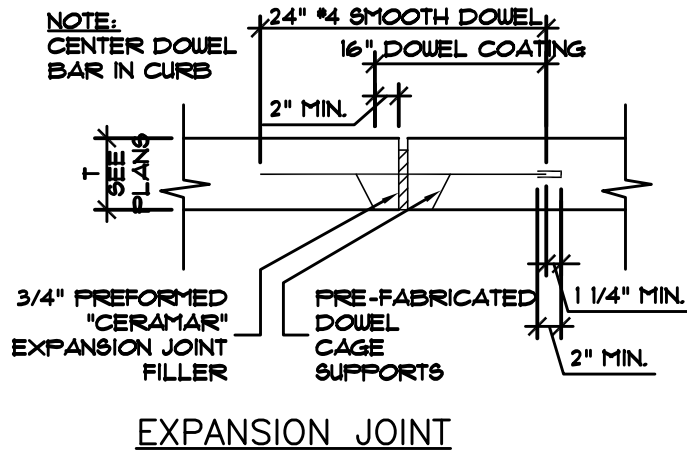
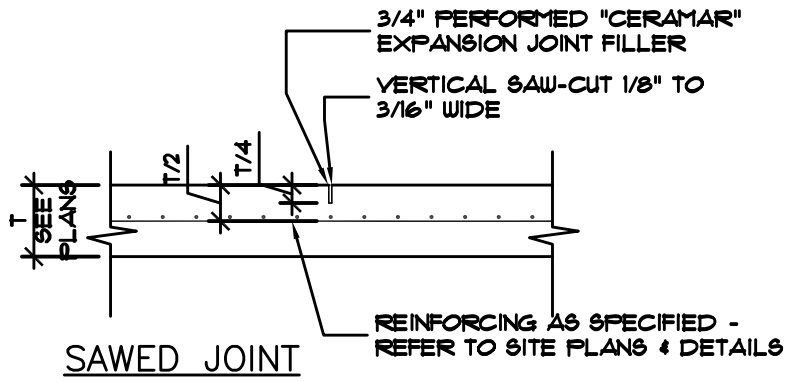

DETAIL - TYPICAL JOINTS

TYPICAL JOINT DETAILS

SCALE: 3/4" = 1'-0"